

AN INSTRUMENT FOR THE DEVELOPMENT OF THE ENTERPRISE ARCHITECTURE PRACTICE

Marlies van Steenbergen, Martin van den Berg
Architecture & Business Solutions, Sogeti Netherlands B.V., The Netherlands
marlies.van.steenbergen@sogeti.nl, martin.vanden.berg@sogeti.nl

Sjaak Brinkkemper
Department of Information and Computing Sciences, Utrecht University, The Netherlands
s.brinkkemper@cs.uu.nl

Keywords: Enterprise Architecture, Maturity models, Architecture Maturity Matrix, Software Process improvement.

Abstract: In this paper we introduce an architecture maturity model for the domain of enterprise architecture. The model differs from other existing models in that it departs from the standard 5-level approach. It distinguishes 18 factors, called key areas, which are relevant to developing an architectural practice. Each key area has its own maturity development path that is balanced against the maturity development paths of the other key areas. Two real-life case studies are presented to illustrate the use of the model. Usage of the model in these cases shows that the model delivers recognizable results, that the results can be traced back to the basic approach to architecture taken by the organizations investigated and that the key areas chosen bear relevance to the architectural practice of the organizations.

1 MATURITY IN ENTERPRISE ARCHITECTURE

Increasing complexity in the overall information systems portfolio of an organization, and especially in the integration of information systems, requires enterprise architecture as a guiding principle. For this to work, sound architectural practices have to be implemented.

Enterprise architecture, however, is a relatively young field (Bucher et al, 2006), (Lankhorst et al, 2005). Architectural practices still have to be established. There appears to be a need for an instrument to support and accelerate this.

In this paper we will introduce such an instrument. We will start with distinguishing three basic types of architecture maturity models: the staged 5-level models, the continuous 5-level models and the focus area oriented models. Enterprise architecture being a relatively young discipline, we feel that at the moment most organizations benefit best from the focus area oriented model. We will therefore introduce an architecture maturity matrix that falls into this category.

1.1 Architecture Maturity Models

Most maturity models are concerned with software development and maintenance. The most widely used is CMM and all its variants (CMML, 2002). Recently some architecture maturity models have been developed. These models are all based on the generic 5-level maturity model used by CMM. Two variants can be distinguished.

1. *Staged 5-level models.* These models distinguish five levels of maturity. For each level a number of focus areas are defined specific to that level. These focus areas have to be implemented satisfactorily for the organization to achieve that particular level.
2. *Continuous 5-level models.* These models also distinguish five general maturity levels and a number of focus areas. The difference with the first kind of models is that the focus areas are not attributed to a level, but within each focus area the 5 levels are distinguished.

Searching for models that were not build around the standard five maturity levels, we also looked at

other process maturity models and found a third type of model from test process improvement (Koomen and Pol, 1999):

3. *Focus area oriented models.* These models depart from the idea that there are five generic maturity levels. Instead each focus area has its own number of specific maturity levels. The overall maturity of an organization is expressed as a combination of the maturity levels of these focus areas.

The differences between the types of models is illustrated in figure 1.

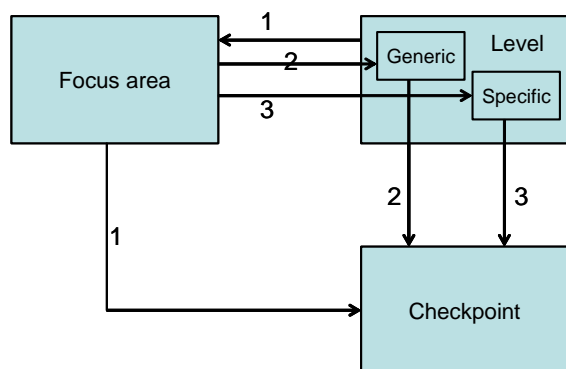

Figure 1: Three kinds of architecture maturity models.

Looking at the three types of model, we prefer the focus area oriented model because it allows a more fine-grained approach, making it more suitable to our purpose of developing and improving the architectural practice, rather than merely assessing its current maturity:

- The focus area oriented model makes it possible to distinguish more than five overall stages of maturity. This results in smaller steps between the stages, providing more detailed guidance to setting priorities in developing the architectural practice.
- Departing from the five fixed maturity levels makes the focus area oriented model more flexible in defining both focus areas and interdependencies between focus areas. In our opinion this better fits the current state of maturity of the architectural practice, where complex combinations of many different factors determine its success.

The application of the first two kinds of models to architectural processes can be found in the literature in various forms. The US Government Accountability Office uses a staged model (GAO, 2003). Examples of the continuous model can be

found in (Appel, 2000), (METAgrou, 2001), (NASCIO, 2003) and (Westbrock, 2004). The continuous model may also be found as foundation for various kinds of organization readiness assessments like for instance the Net Readiness Scorecard that measures the preparedness of an organization to make use of the internet-based economy (Hartman et al, 2000).

Application of the third kind of model to architectural practice we have not encountered yet. This is why we decided to develop a model based on the third type ourselves, the architecture maturity matrix.

Another approach to organizational improvement is the balanced scorecard approach (Kaplan and Norton, 1992). The balanced scorecard is used to evaluate corporate performance, not only on financial aspects but also on customer perspective, internal processes and learning capability. The balanced scorecard concept has also been applied to the IS function (Martinsons et al, 1999). The main difference between the balanced scorecard approach and the model presented in this paper is that the balanced scorecard is concerned with setting specific performance goals, while our approach is concerned with how to reach such goals.

1.2 DYA

The development of the architecture maturity matrix is part of a wider programme, called Dynamic Architecture (DYA), of building a vision on how to develop and improve an effective architectural practice (Wagter et al, 2005), (Van den Berg and Van Steenbergen, 2006). DYA is founded on the following basic principles:

- *The architecture process is as important as the architecture products.* It is no use developing perfect architectural products if no attention is being paid to the embedding of these products in the organization.
- *Architecture facilitates change.* Architecture is a management instrument intended to give direction to the changes that are continuously taking place in an organization.
- *Just enough, just in time architecture.* The development of architecture must be driven by business needs.
- *Deviations from the architecture are allowed, but in a controlled way.* A process must be implemented of managing justified deviations from the architecture.

One of the important lessons we learned in the DYA programme is that an architectural practice within an organization, once it gets its first results, is often swamped by requests, demands and high expectations from both business management and IT personnel. So much so, that they threaten to be defeated by their own success, trying to take up everything at once, thus being bogged down in activities that over time do not appear to result in true value for the company. It is this realization that drove us to developing the maturity matrix to assist in the development process of an architectural practice, and especially, to assist in setting the right priorities.

We have been using the maturity matrix over the last five years in about 20 large organizations in different sectors. In the remainder of this paper we will discuss two of these cases, a manufacturing company and a semi-governmental organization. We will discuss major findings and lessons learned of the cases studied. But first we will explain the architecture maturity matrix in more detail in the next section.

2 ARCHITECTURE MATURITY MATRIX

In this section we explain the structure and use of the enterprise architecture maturity matrix.

2.1 Structure of the architecture maturity matrix

Key element of our approach is the realization that many factors determine the success of enterprise architecture, but that at different points in time, different aspects need attention. So we searched for a model that would support this differentiation in factors. We adopted the model from the Test Process Improvement (TPI) model (Koomen and Pol, 1999). We adopted the structure of the TPI model, but translated it from test processes to architectural processes. Figure 2 shows the resulting matrix. For an extensive explanation of the matrix we refer to (Van den Berg and Van Steenberghe, 2006).

The matrix distinguishes 18 key areas that are important to the architectural practice. Each of these key areas has its own maturity growth path consisting of two to four maturity levels, depending on the actual key area. These maturity levels per key

Area	Scale	0	1	2	3	4	5	6	7	8	9	10	11	12	13
Development of architecture			A			B			C						
Use of architecture			A			B				C					
Alignment with business			A			B				C					
Alignment with the development process			A			B			C						
Alignment with operations					A			B			C				
Relation to the as-is state					A				B						
Roles and responsibilities				A		B					C				
Coordination of developments					A			B				C			
Monitoring				A		B									
Quality management							A		B		C				
Maintenance of the architectural process							A			B		C			
Maintenance architectural deliverables						A			B				C		
Commitment and motivation			A							B		C			
Architecture roles and training				A		B					C			D	
Use of an architectural method					A							B			C
Consultation			A			B				C					
Architectural tools							A						B		C
Budgeting and planning														B	C

Figure 2: Architecture maturity matrix.

area are depicted by the letters A to D in the matrix. For example the key area *use of architecture* has three maturity levels *architecture used informatively* (A), *architecture used to steer content* (B) and *architecture integrated into the organization* (C).

The position in the matrix of the letters indicating the maturity levels for each key area is fixed. It indicates the relative priorities of the 18 key areas. The matrix should be read from left to right. The first A's to be encountered are the first key areas to pay attention to if one wants to develop an architectural practice. Figure 2 shows that these are the key areas *development of architecture*, *alignment with business* and *commitment and motivation* (the A's in column 1). These key areas should be developed to their first maturity level (A), before work is done on the key areas *use of architecture*, *alignment with the development process* and *consultation* (the A's in column 2). And so on. Only if all A's in columns 1 to 3 have been achieved, is it advisable, according to the matrix, to develop the key area *development of architecture* to the next level (the B in column 4). In this way the matrix can be used to set priorities in developing the architectural practice.

Each level of each key area is associated with one to four checkpoints. For instance level A of key area *use of architecture* has as one of its checkpoints whether the architecture is accessible to all employees. The matrix is used as an assessment instrument by scoring the checkpoints. All checkpoints belonging to a level have to be scored positively to achieve that level. In total there are 137 checkpoints.

Each level of each key area is also associated with one to three suggestions for improvement. They represent best practices that may help an organization to satisfy the checkpoints.

2.2 Use of the architecture maturity matrix

The architecture maturity matrix is an assessment instrument to be used by an outside party to evaluate the current state of the architectural practice of an organization.

Usually, an assessment is commissioned by the person responsible for the architectural function. This may be the head of the architects, the head of the IT function or the CIO. The assessment is often the first step in a structured improvement process.

The assessors, usually as a team of two, complete the matrix by scoring all 137 checkpoints. They do this on the basis of interviews, studying architectural documents, and making use of a questionnaire.

The interviews are with all relevant stakeholders, being senior management, business managers, project managers, system developers, operations and architects. This is required because a successful architectural practice depends on the measure in which the various disciplines in the organization understand and accept the purpose and content of the architecture. This relation of architecture to other disciplines is therefore reflected in the key areas the matrix contains.

Study of the documentation is primarily meant to gauge the width and depth of the architectural artefacts.

To support the picture the assessors build for themselves, a questionnaire can be issued to architects, project managers and line management. However, this has to be regarded with care, as the questions are open to interpretation. The authors use the questionnaire for two purposes:

- to validate the picture they receive from the interviews; if the questionnaire outcome differs greatly from the findings from the interviews, the assessors have to dig deeper.
- To gain insight in possible differences in perception from the different stakeholders. By distinguishing the overall scoring of different disciplines differences in perception may occur. This provides clues to the measure of general acceptance and the extent to which views on architecture are shared throughout the organization.

Differences in perception between stakeholders are thus one of the indications of the level of architecture maturity and are as such reflected in the outcome of the matrix.

The completed matrix is included in an assessment report, together with a discussion of the key findings as well as recommendations for improvement.

Some organizations choose to perform an assessment each year, using the results to feed a continuous improvement process. Reported results from such an improvement process include lower IT costs, better cooperation between business and IT and shorter response times of IT.

3 CASE STUDIES

In the period of 2002 to 2006 the maturity matrix has been used in different organizations. The matrix has been applied to about 20 organizations in the private and public sector: finance, government, healthcare, industry, utility, telecommunications and retail. The size of the organizations ranges from a couple of hundred to tens of thousands of employees. Both national, international and multinational companies have been assessed.

In this section we present two case studies: first we give a brief description of the kind of organization we are looking at, followed by the basic approach to architecture we encountered. Then we present the matrix we completed for the organization and discuss how the scores on the key areas can be related to its basic approach to architecture. For completion's sake we will also say a few words on the kind of advice that we gave based on the outcomes of the assessments.

3.1 A manufacturing company

The first case is of a multinational manufacturing company. The company has plants in various parts of the world and has about 23,000 employees worldwide. The IT department consists of about 600 employees. The architectural team is positioned within the IT department which consists of an American branch and a European branch. Architects are positioned both at headquarters in the US and in Europe. In total the architectural team consists of about six enterprise architects. Architecture has been worked on for about three years.

The basic approach taken to architecture is a technology-oriented approach. Architecture development is being done primarily from an IT perspective and concentrates on technical infrastructure. Standardization in the technological field is an important aim. About 30 practitioners are each laying down the standards and roadmaps for

their specific technological areas. These standards are made available to all by means of the company intranet.

As a consequence of this approach architecture is very much a collection of technological standards. There is no overall, comprehensive vision of business choices, processes and information systems. Also, among the persons writing the standards, there is no common understanding of what architecture entails and what goals it has to achieve.

The director of architecture in the US asked for an assessment of the architectural processes to provide input for next year's architecture development plan and strategy. The assessment was performed within four intense days. One day was reserved for interviews and studying documentation, one day and a half for analysing the data and one day and a half for presenting and discussing the results. Beforehand the enterprise architects had completed the questionnaire, which was used as background information to the assessment.

The matrix that resulted from completing the checkpoints is given in figure 3.

Area	Scale	0	1	2	3	4	5	6	7	8	9	10	11	12	13
Development of architecture			A			B			C						
Use of architecture			A				B				C				
Alignment with business			A				B				C				
Alignment with the development process			A				B			C					
Alignment with operations					A				B		C				
Relation to the as-is state					A					B					
Roles and responsibilities				A		B					C				
Coordination of developments							A			B					
Monitoring				A		B		A	C	D					
Quality management								A		B			C		
Maintenance of the architectural process								A		B		C			
Maintenance of architectural deliverables						A							C		
Commitment and motivation		A						B		C					
Architecture roles and training				A			B					D			
Use of an architectural method				A							B				C
Consultation			A			B				C					
Architectural tools							A					B			C
Budgeting and planning				A								B		C	

Figure 3: Maturity matrix for the manufacturing company.

The matrix shows that the key areas to focus on for this organization are *alignment with business*, *use of architecture* and *consultation*.

The low score on *alignment with business* is caused by the fact that no clear link can be established between the architectural products and the business strategy and goals, as well as by the fact that the architecture is not evaluated in terms of the business goals. The checkpoints 'Is there a clear relationship between the architecture and the organization's business goals?' and 'Is the architecture evaluated in terms of the business goals?' are answered negatively. This reflects the fact that architecture has emerged from individual expertise, not from a company-wide vision.

The key area *use of architecture* failed on the checkpoint whether the architecture provides a clear picture of the organization's goals and demands.

The low score for *consultation* is caused by the fact that though meetings of the architects were being held, no outcomes or decisions were being recorded.

Striking in the matrix is the relatively high score for *alignment with the development process*. The fact that the standards were being developed by the practitioners themselves resulted in a strong buy-in from the technical community. This made for a strong embedding of the architecture principles in the development process. Which helped a lot in getting projects to adhere to the architecture. Hence the high score for this key area.

The scores of the key areas can be straightforwardly explained from the basic approach to architecture. The specialist technology-oriented approach is directly reflected in the low scores for *alignment with business*, *use of architecture* and *consultation*, but also leads to the relatively high score for *alignment with the development process*.

The advice given to the company on the basis of the assessment (with the related key areas between brackets) was to:

- Strengthen the business - IT alignment by explicitly linking the architectural choices to the business goals (*alignment with business; use of architecture*).
- Create an architecture community of enterprise and domain architects that work together, exchange ideas and share a common framework (*consultation*).
- Strengthen the efforts in information architecture to start closing the gap between technology and business goals (*alignment with business*).

The matrix proved a useful instrument in providing input to the architecture development plan and strategy. It helped the organization to focus on the right measures to improve their overall maturity. Its major contribution lay in the integral approach to architecture reflected in the balance between the levels of the 18 key areas. The matrix helped to show the overall picture and gave clear insight in the strengths and weaknesses of the architectural practice so far. These strengths and weaknesses were, once they were exposed, clearly recognizable to the organization: the lack of a shared vision, partly because of the missing link to the business strategy, which prevented the move from individual

technology standards to a comprehensive view on the right information structure for the company.

3.2 A semi-governmental organization

The second case concerns a Netherlands semi-governmental organization. The organization has about 500 employees. At the moment of assessment, the organization underwent a transition from a purely government funded organization to an organization that was commercially active on the free market.

This transition had a huge impact on the culture and processes of the organization. Internal processes and products became commercially exploitable services. This asked for greater standardization and flexibility. The organizational thinking had to be turned from internal product oriented to external process oriented.

The organization had been working on architecture for a year before they approached one of the authors. They had appointed three consultants from the IT staff department to act as architects. One of these three clearly functioned as the frontman. Architecture was mainly associated with his name. The rest of the IT department was not actively involved in the architectural efforts.

The basic approach chosen by the organization was a project-driven one. As they put much value on commitment from the organization the architects had focused primarily on providing support to business projects. In this way they had built, over the year, a number of process and application models. These were delivered to the projects. The need-based, just enough, just in time approach ensured a clear link between the architectural models and the business goals. They also engendered awareness of architecture, especially with management. However, the architecture products were not consolidated into an enterprise architecture, nor were they made easily accessible to the rest of the company. Because of the lack of an overall enterprise architecture to relate the various models to, the architecture as a whole was rather fragmented. There were architectural products, there was no overall, comprehensive enterprise architecture.

As the architects were uncertain how to proceed they asked one of the authors to perform an assessment and provide recommendations for improvement. We performed eight interviews with project managers, team managers, directors and architects and fifteen employees completed the questionnaire. The assessment took six days over a

period of four weeks. On the basis of this, the following picture emerged.

Area	Scale	0	1	2	3	4	5	6	7	8	9	10	11	12	13
Development of architecture			A			B			C						
Use of architecture			A			B					C				
Alignment with business			A			B					C				
Alignment with the development process			A				B			C					
Alignment with operations						A			B			C			
Relation to the as-is state										B					
Roles and responsibilities					A		B					C			
Coordination of developments							A				B				
Monitoring					A		B		C		D				
Quality management								A		B			C		
Maintenance of the architectural process								A		B		C			
Maintenance of architectural deliverables						A			B				C		
Commitment and motivation			A					B		C					
Architecture roles and training					A		B			C				D	
Use of an architectural method					A						B				C
Consultation			A			B				C					
Architectural tools							A					B			C
Budgeting and planning					A								B		C

Figure 4: Maturity matrix for the semi-governmental organization.

The matrix in figure 4 shows the organization is at scale 1. The key areas to work on in order to reach the next maturity level are *use of architecture* and *consultation*.

Alignment with business scores relatively high. This can be explained from the fact that architecture development was project, and hence business goal, driven.

However, the results of these project-driven development activities were not consolidated into a readily accessible enterprise architecture. Hence the low score on *use of architecture*. This key area failed on the checkpoints whether there is an architecture that is recognized by management as such, whether the architecture gives a clear indication of what the organization wants and whether the architecture is accessible to all employees.

The fragmentation of the architecture was also shown in the lack of teamwork indicated by the low score for the *consultation* key area: there are no regular meetings of the architects, nor are any decisions made properly documented.

In this case too, the scores on the various key areas can be traced back to the basic approach taken to architecture.

The advice given to the organization on the basis of the assessment was to:

- Develop an overall enterprise architecture (*use of architecture*).
- Spread architectural awareness and involvement throughout the organization (*consultation*).
- Publish the architecture (*use of architecture*).
- Bring all projects under architecture (*monitoring*).

Again, the matrix proves useful in bringing the message home, especially because it shows the relations between the various aspects relevant to the architectural practice. The scores were recognizable and the matrix helped in the communication about the strengths and weaknesses and their consequences. The assessment stimulated the organization to start work on the overall framework to position their individual architectural artefacts and to broaden the base for architectural thinking and acting from essentially one person to employees from all parts of the organization.

3.3 Results and matrix adjustments

The identification of the key areas, their levels and their positioning in the matrix was initially based on practical experience. From our work in various organizations establishing architecture practices we distilled the key areas and their relative priorities. The first version of the matrix stems from 2001 and was published in 2003 (Van den Berg and Van Steenbergen, 2003).

Validation of the matrix took place primarily by applying the instrument to about 20 real-life cases. In all cases the results of the completed matrix met with much recognition from both management and architects. The strengths and weaknesses that emerged were recognized, as well as the priorities that were suggested by the matrix.

Secondly, as illustrated in the case studies, the scores on the key areas in the matrix could typically be traced back to the basic architectural approach of the organizations investigated. In the manufacturing company the low and high scores of the key areas could be recognizably linked to the individualistic technology-oriented approach. The same is the case for the relation between the scores of the semi-governmental matrix and its project-driven approach.

Finally, application of the first version of the matrix for two years led to a number of adjustments. The fact that these adjustments presented themselves and could be motivated can be seen as an indication of the relevance of the key areas chosen. The following changes were made:

- We changed the focus of the key area *maintenance of architectural process* from quality improvement to more general management of the process. This was motivated by the realization that we had focused too strongly on quality management, which is a separate key area, while neglecting

more basic process management aspects like describing and communicating your processes.

- We moved level B for the key area *maintenance of architectural deliverables* from column 6 to column 7. This is a minor change, prompted by the wish to bring a bit more balance in the matrix as a whole. The other letters in column 6 had higher priority in our eyes than level B of this key area.
- We moved level B for the key area *use of an architectural method* from column 11 to column 9. This move is motivated by the increasing need felt for having architects throughout the organization working together. This is made easier when they share a common approach to architecture.
- We moved level A for the key area *architectural tools* from column 8 to column 6, and level B from column 11 to column 10. While we remain wary of introducing tools into an organization at too early a stage, causing the organization to focus on the tool instead of on the content required, this move is motivated by the fact that tools are beginning to appear that are less daunting and more flexible in use. This reduces the risk of the tool dictating the architecture.
- We moved level A for the key area *budgeting and planning* from column 6 to column 3, and level C from column 13 to column 12. This move sprang from our experience that architects may tend to keep working on their architecture until perfection, without a sense of having to deliver in time. Therefore we stress the importance of drawing up a plan of approach before embarking on an architecture development project. We found it such an important aspect in making architects more effective that we moved the levels for this key area forward.

For the last three years the matrix has been stable and we do not anticipate any major changes. However, as the enterprise architecture field matures, minor adjustments may be called for sometime in the future.

3.4 Lessons learned

From applying the maturity matrix in about 20 organizations in the course of five years, we learned the following lessons:

- *When assessing an organization more than one matrix may be required.* In an early case

of applying the matrix, we had a hard time scoring the checkpoints. We seemed to encounter contradictory signals which made it extremely hard to decide on a yes or no. Until we realized that the organization really consisted of two worlds: a new world introducing new software techniques in one of the business units of the organization and the rest of the organization which continued on the existing road of years before. Once we tried to score the two worlds separately, everything fell into place. The new world scored a clear level 2, while the old world was stuck on level 0. This reflected a risk of the new world losing the connection with the old world. We therefore advised for the new world to strive for improvement to level 3, while the old world was to go for level 2, in this way closing the gap, while the new world was allowed to retain its innovative lead.

- *Using the checkpoints as a questionnaire may provide additional insight.* The checkpoints are meant as a formal instrument to complete the matrix. However, in the course of time we found that when they are converted to a questionnaire they may fulfil additional purposes. For one thing we have encountered a number of times the fact that the various stakeholders in an organization differ in their view of the architectural practice. These are valuable clues to interpreting the actual situation. Another use of the checkpoints as questionnaire is to have a delegation of the organization complete the questionnaire together. This kind of self assessment appears to provoke very useful discussions and sharing of experiences and best practices. Completion of the questionnaire by a group of about six persons takes about an hour and a half. We frequently use it as an instrument in awareness and improvement workshops for architectural teams.
- *Using the checkpoints as a questionnaire is not reliable as single input for an assessment.* This lies mainly in the fact that situations and perceptions differ throughout the organization. For instance, some projects may be monitored by architects while others are not. As the checkpoints ask for a clear yes or no, different people may provide different answers. It is therefore to be left to the assessors to do the final scoring of the checkpoints if a formal assessment is asked for.

- *The assessment is organization independent, but the improvement suggestions are not.* The completion of the checkpoints is done in a standard way for each organization. Thus the identification of strengths and weaknesses does not differ from organization to organization. The actual advice for improvement, however, is very organization specific. The scoring of the matrix provides insight into the aspects that have to be addressed and improved. The best way to go about improving these aspects is very much driven by factors like culture, size, business and overall process maturity of the organization.

4 DISCUSSION AND CONCLUDING REMARKS

The matrix has held, apart from a few adjustments motivated by changes in the field, for five years now, being applied to organizations of different branches and different sizes. Most organizations, however, have scored in the lower regions of the matrix (levels 0 to 3). It is imaginable that, when maturity grows and organizations get higher scores, the matrix will receive another update. The authors see this as a strength of the matrix, rather than a weakness.

Until now, the positioning of the key area levels in the matrix has held for all organizations investigated. An interesting question that comes up is if this will remain the case when organizations move to the right in the matrix. In future it might appear that a distinction in types of organizations may be required. I.e. different matrices for different organizations. Our expectation is that a differentiation in the choice of key areas is not required, but that the relative positioning to each other of the key area levels, i.e. the setting of priorities, may vary. This is an issue for further research.

The matrix provides insight and support to improve the architectural practice of an organization. It is aimed at making architectural practices run more smoothly and making them better accepted by the rest of the organization. What remains to be done is to measure whether these better running practices do indeed lead to better performance of the organization as a whole, or in other words, whether the contribution of architecture to the business goals improves as well.

The focus of the matrix has grown to be more on guiding improvement than on measuring maturity. In a field as young as enterprise architecture we think this is a justified choice.

So far the matrix seems to be a very useful instrument in assessing the strengths and weaknesses of the architectural practice of organizations and in providing direction and priorities for improvement. Use in practice shows that the results are recognizable and the improvement suggestions feasible. A number of organizations have even used the matrix to give direction to an improvement trajectory of years, performing a yearly assessment to monitor progress.

ACKNOWLEDGEMENTS

We would like to thank Rogier Dijk and Joost Luijpers for their contributions to the development of the first version of the architecture maturity matrix. Rik Bos, Wiel Bruls and Ralph Foorhuis we thank for their comments on an earlier version of this paper. Last but not least we want to thank the anonymous reviewers for their suggestions for improvement.

REFERENCES

- Appel, W., 2000. Architecture Capability Assessment. In *Enterprise Planning & Architecture Strategies*, vol.4, nr.7, METAGroup.
- Berg, M. van den, Steenbergen, M. van, 2003. Niveaus van werken onder architectuur (Levels of architectural maturity). In *Informatie*, vol. 45, nr. 2, pp. 52-56.
- Berg, M. van den, Steenbergen, M. van, 2006. *Building an enterprise architecture practice*. Springer, Dordrecht.
- Bucher, T., Fischer, R., Kurpjuweit, S., Winter, R., 2006. Enterprise Architecture Analysis and Application - An Exploratory Study. In *EDOC workshop TEAR 2006*. Hong Kong. Retrieved November 22, 2006, from tear2006.telin.nl.
- CMMI, 2002. *CMMISM for Systems Engineering, Software Engineering, Integrated Product and Process Development, and Supplier Sourcing; (CMMI-SE/SW/IPPD/SS, V1.1) Staged Representation; CMU/SEI-2002-TR-012 ; ESC-TR-2002-012* .
- GAO, 2003. *A framework for assessing and improving enterprise architecture management*.
- Hartman, A, Sifonis, J., Kador, J., 2000. *Net Ready: Strategies for Success in the E-conomy*. McGraw-Hill, New York.
- Kaplan, R., Norton, D., 1992. The balanced scorecard: measures that drive performance. In *Harvard Business Review*, vol. 70, nr. 1, pp. 71-79.
- Koomen, T., Pol, M., 1999. *Test Process Improvement, a practical step-by-step guide to structured testing*. Addison-Wesley, Boston.
- Lankhorst et al, 2005. *Enterprise Architecture at Work*. Springer, Heidelberg.
- Martinsons, M., Davison, R., Tse, D., 1999. The balanced scorecard : a foundation for the strategic management of information systems. In *Decision Support Systems* vol. 25, pp. 71-88.
- METAGroup, 2001. *Diagnostic for Enterprise Architecture*, META Practice.
- NASCIO, 2003. *NASCIO enterprise architecture maturity model*.
- Wagter, R., Berg, M. van den, Luijpers, L., Steenbergen, M. van, 2001. *Dynamic Enterprise Architecture: how to make it work*. Wiley, Hoboken.
- Westbrock, T., 2004. *Architecture Process Maturity Revisited and Revised*. METAGroup Delta 2902.